

## ***Multipoint Purge System Installation***

Each K-Bar has its own purge gas solenoid which is activated from one of the sensor control boards (SC) via its Relay 2 output terminals. This is a 24 VDC, 12 W signal. Each K-Bar may need its own blow down tank. If the lengths are not so long as to drop the gas pressure too much (peak flow during cleaning 120 SCFM/sensor), blow down tanks can be shared.

### **Cleaning Gas Requirements**

Table AG-1. Gas requirements per sensor for purge cleaning.

<b>Gas</b>	Clean Air or inert gas
<b>Pressure</b>	105 PSIA +/- 30 psi
<b>Purge Consumption per Sensor</b>	2 SCF/purge @ 1 second valve open time ~120 SCFM flow rate when valve is open.
<b>Bleed Flow Rate per Sensor</b>	0.1 SCFM

For a 4 point K-BAR, the peak purge consumption is almost 500 SCFM and the bleed flow rate is 0.4 SCFM. This is why you need significant pipe size (ie: 1") and short distance (ie: 20' or less) between the blow-down tank and K-BAR

### **System Wiring**

The common purge initiation contact closure (see field wiring drawing [342040](#)) is feed from the Kurz model 148 purge timer. The 148 provides the cycle interval, and K-bar sequencing so only one bar on a stack or process is cleaned at a time. This limits the air supply requirements and permits blow down tanks to be shared in many cases.

Typical Wiring between the 148 timer and 4 bar system with K-BAR-2000PB is a single wire pair, ground and contact closure from the timer to the K-BAR. Table AG-2 shows the 8 wires needed on a four K-BAR system.

Table AG-2. Example wiring between the 148 purge timer and K-BARs in a 4 bar application.

Cable #	Kurz 148 Timer	K-BAR-2000PB
1	Bar 1 output, TB3 -	K-BAR #1 TB-1 Purge
1	Bar 1 ground, Chassis GND	K-BAR #1 TB-1 GND
2	Bar 2 output, TB4 -	K-BAR #2 TB-1 Purge
2	Bar 2 ground, Chassis GND	K-BAR #2 TB-1 GND
3	Bar 3 output, TB5 -	K-BAR #3 TB-1 Purge
3	Bar 3 ground, Chassis GND	K-BAR #3 TB-1 GND
4	Bar 4 output, TB6 -	K-BAR #4 TB-1 Purge
4	Bar 4 ground, Chassis GND	K-BAR #4 TB-1 GND

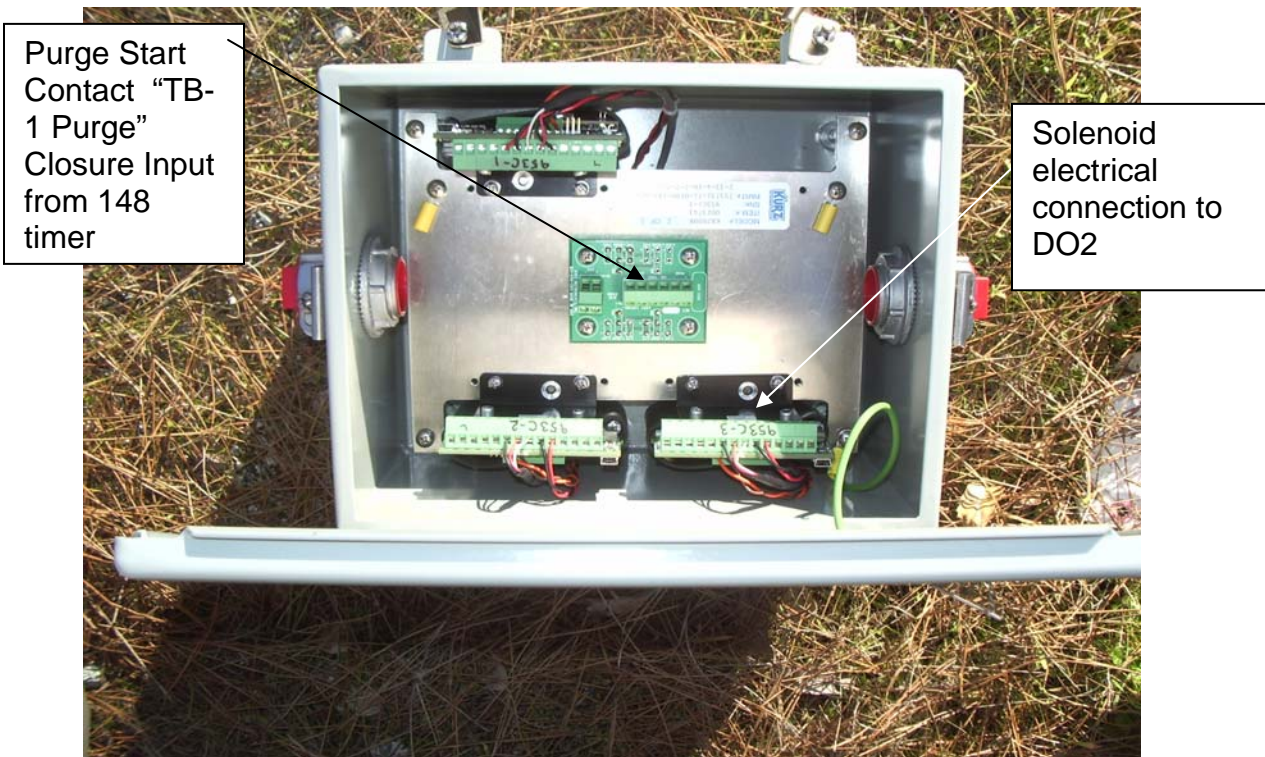

Figure AG-1. K-Bar-2000 electronics enclosure.

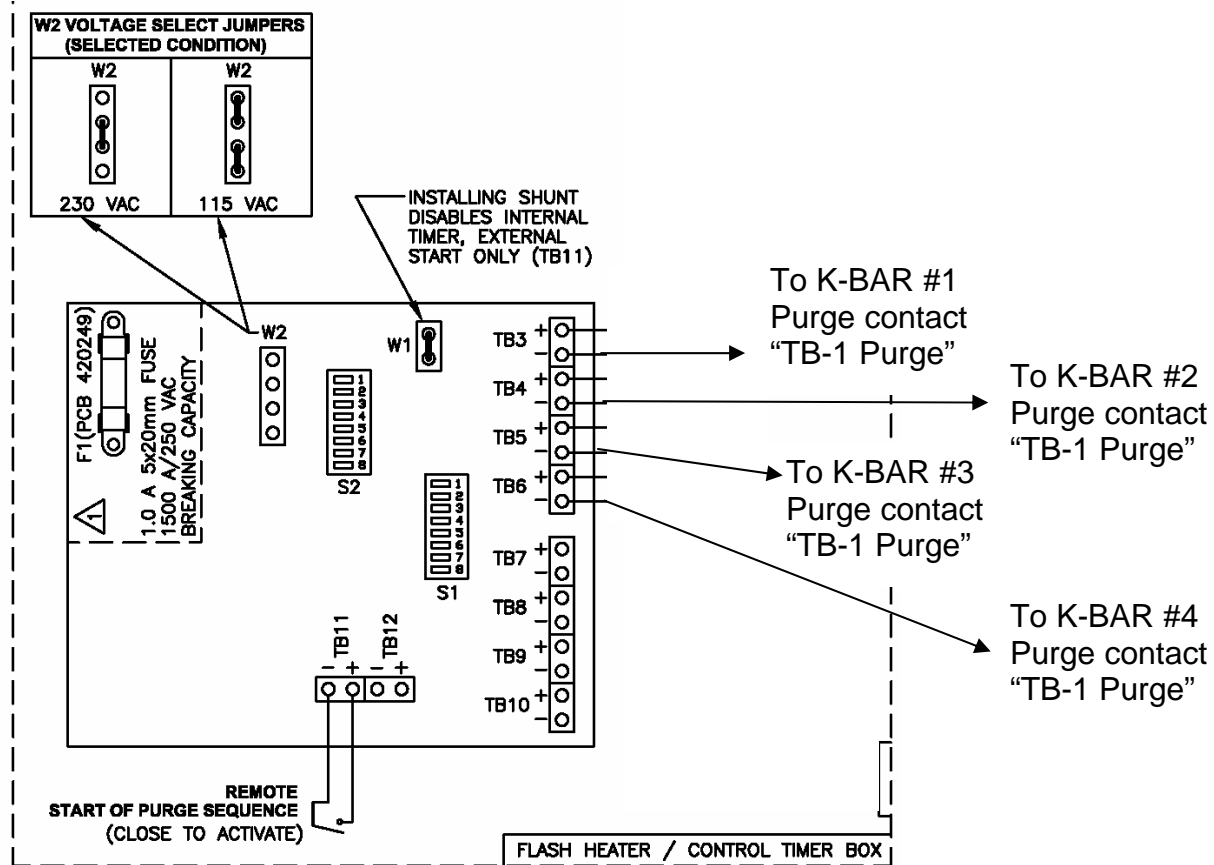

Figure AG-2. Model 148 Multipoint Purge Controller circuit board (mounted in a 5x7 fiber glass enclosure)

### Purge Timer Control, Model 148.

The purge timer control is accomplished with circuit board DIP switches and shunts. It has open collector outputs which are tied to the K-BAR purge cycle activation or trigger pin (TB-1 Purge)

### Purge Cycle Time

The purge timer is designed to clean several velocity sensors in a stack with each probe on its own control valve. A stack with four probes would clean each separately, allowing the blow-down tank to re-charge between each blast. The timer waits some programmed *interval* then starts the cleaning sequence again with a preset *recovery* time between probes. The *cycle time* is the sum of the *interval time* and *recovery time*. Figure AG-3 explains the timing and nomenclature for this operation. Note that for a single sensor

cleaning or one bar application, the *recovery* time is ignored so the *cycle* time equals the *interval* time.

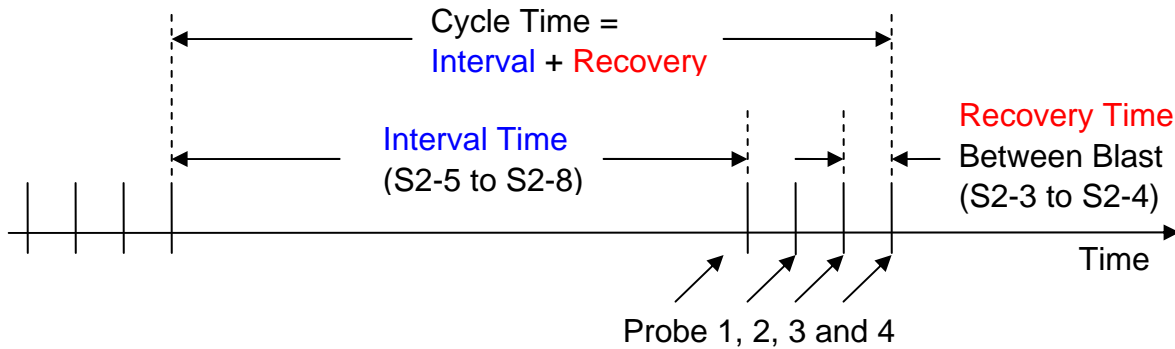

Figure AG-3. Purge Timer Nomenclature.

*Example cycle time calculation:*

*4 K-BAR system, 2 minute recovery time and 60 minute interval time.*

$$\text{Cycle Time} = 2 \times 4 + 60 = 68 \text{ minutes}$$

### **Purge Valve Open Time (Blast Pulse Width)**

This is done in the K-BAR-2000PB SC boards. See [section P](#) for programming instructions.

### **Data Hold Time during a Purge**

This is done in the K-BAR-2000PB SC boards. See [section P](#) for programming instructions.

### Recovery Time Between Purges

On a multiple probe application, one purge timer can control many K-BARs. The blow-down tank recovery time between blast is programmed with S2-3 and S2-4. The following table defines this delay. When the timer is waiting between probe blast to re-charge the tank, the LED D13 near the TB11 will be illuminated. *Note: Fine adjustment of this time is done via R12 but is factory set.*

Recovery Time (minuets)	S2-3	S2-4
2.0	Open	Open
4.0	Closed	Open
6.0	Closed	Closed

### Purge Interval Time

The interval between the last purge and the next sequence is set by the DIP switch S2 at locations 5 to 8 in a binary code with each value worth 5 minutes. Again, 1 means closed, 0 means open. *Fine adjustment of this time is done via R14 on the PCB and has been factory set.*

Interval Time (minuets)	S2-5 (5)	S2-6 (10)	S2-7 (20)	S2-8 (40)
5	1	0	0	0
10	0	1	0	0
15	1	1	0	0
20	0	0	1	0
25	1	0	1	0
30	0	1	1	0
35	1	1	1	0
40	0	0	0	1
45	1	0	0	1
50	0	1	0	1
55	1	1	0	1
60	0	0	1	1
65	1	0	1	1
70	0	1	1	1
75	1	1	1	1

### Number Of Purge Bars Controlled Per Cycle

You can set from 0 to 8 bars per timer cycle. S1 selects the last K-BAR connected with a straight one-one-bit mapping selection. You must select just one switch position, if not, the timer will not operate properly.

Active K-BARs in cleaning sequence	S1-1	S1-2	S1-3	S1-4	S1-5	S1-6	S1-7	S1-8
1	1	0	0	0	0	0	0	0
2	0	1	0	0	0	0	0	0
3	0	0	1	0	0	0	0	0
4	0	0	0	1	0	0	0	0
5	0	0	0	0	1	0	0	0
6	0	0	0	0	0	1	0	0
7	0	0	0	0	0	0	1	0
8	0	0	0	0	0	0	0	1

### Remote Start Of The Purge

The purge sequence can be remotely started by closing the two contacts at TB11, pins 1 and 2. This is a 24 VDC control signal. If an external start is preferred to the internal interval timer, then the W1 shunt may be installed which disables the internal interval timer. Once the sequence is started, the number of K-BARs and recovery time are still applicable.

### Acknowledgement Output Signal

An open collector output (24 VDC max, 30 mA max.) may be used to signal purge operation to customer equipment (PLC for example). This output is on TB12-1 and TB12-2 with, -1 the collector and -2 being a ground. The selection of the optional W3 shunt chooses the output to be coincident with the purge start trigger to the K-BARs. (goes low at start).

#### CASE 1 (Seconds duration)

W3-1 jumpered (shunted) to W3-2 gives a purge trigger signal that goes low for each closure on TB12-1. With a four probe application, there would be an open collector low signal when each probe is cleaned. This pulse is at least 0.5 s but less than 2.0.

#### CASE 2 (Minutes duration)

W3-2 jumpered(shunted) to W3-3 gives the—interval-done or sequence started. The output (TB12-1) goes low until the last K-BAR purge trigger has been given. With a four BAR application, there would be an open collector low signal that would stay low for the entire sequence of cleaning each of the four probes. This would be several minutes long depending on the number of bars and recovery time settings.

No signal is generated at the purge acknowledgement output ( TB12-1 terminal) when the W3 jumper(shunt) is not installed.