



APPLICATION NOTE 364023: Pump Monitoring & Protection

Application(s): Pump Monitoring and Pump (motor) Protection

Product Used: KURZ GOLD 6500 Series Flow – Level – Interface – Temperature Switch.

Description: Provide a rugged *and* reliable means for pump protection and monitoring.

- Shut down the pump (motor) when the (pump) inlet line is dry/empty.
- Automatically re-start the pump when the flow of the process material is restored.
- Provide an alarm when blockages occur in the pipeline.
- React to changes in the flow rate.

Problem: It is difficult to find *one device* that can be configured for a wide variety of flow conditions and will not require frequent maintenance. To perform well in this application, the flow switch must resist failures caused by:

- Corrosion and/or “sludging”.
- Vibration.
- Water contamination – feed water and cooling water often contains sediment and high mineral content.
- Electromagnetic interference from motors etc.
- Difficult and/or controlled access points limit monitoring and daily maintenance.

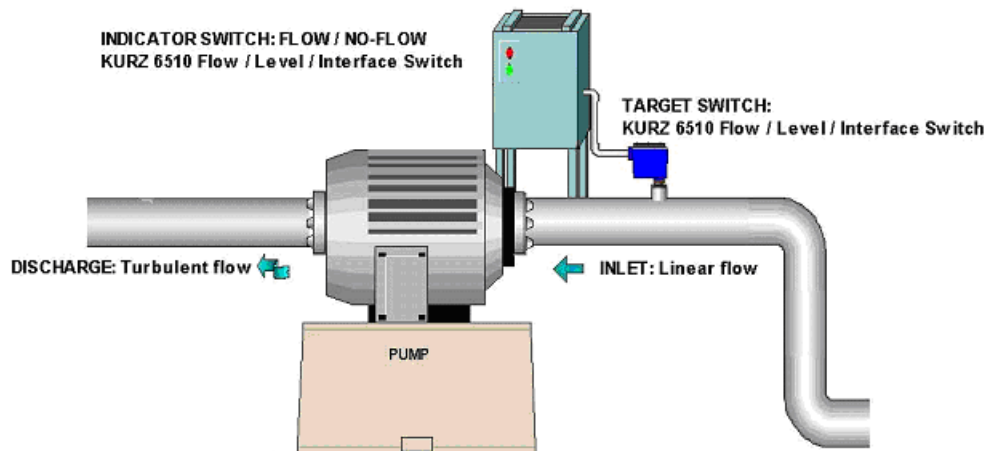

Figure 1 – KURZ GOLD 6510 used in pump protection / monitoring

Solution: Every KURZ GOLD 6500 SERIES Thermal Dispersion Flow, Level, Interface, Temperature Switch is built to be configured by the user for *flow, level, interface level and/or temperature indication in air, gases, oil, water, liquids and slurries*. The digital electronics are configured by the user for each application and are 100% interchangeable.

- Unlike float, paddle or gap switches KURZ switches are built specifically for demanding applications, remote locations and harsh conditions.
- Easy, front panel controls and an LED display make set-up fast and easy.
- No-moving-parts design and all-welded sensors eliminate drift and sensor failures.
- Digital electronics provide precise adjustment and optimum repeatability. No calibration is required.
- Automatic, continuous self-diagnostics with auto-alarm function.

- The **KURZ GOLD 6500** switch may be set to alarm via either of the two (2) independent relay contacts and/or a - 4-20 mA analog output, on *flow* (or increasing) or *no-flow* (decreasing).
- The *heater power, range limits, and relay set point(s)* are independently and incrementally configured and may be quickly and easily adjusted *via the front panel push buttons* (no trimpots!). This allows the **KURZ GOLD 6500 SERIES** switch to achieve application-specific response times and to eliminate “nuisance alarms”.

Bypass Delay Timer: The Bypass Delay Timer makes it possible to disable the pump on low flow and have it restart automatically after a predetermined time.

- The Bypass Delay Timer allows users to set the delay from 0 to 100 seconds, in five-second increments.
- The Bypass Delay Timer is a programmable feature of KURZ’s digital electronics and as such *requires no additional wiring or hardware*.
- In the event of a power interruption the Bypass Delay Timer will automatically re-start the pump at power-on or re-start.
- During the Bypass Delay both relays are energized regardless of their mode or the value of the thermal signal.

Important Guidelines for Installation and Operation in Pump Monitoring Applications:

INLET or OUTLET?: The diagram on Page 1 shows the **KURZ** flow switch installed as a “Target Switch” on the INLET side, and as an “Indicator Switch” on the OUTLET side of the pump.

It is almost always preferable to install the flow switch on the INLET side of the pump.

- The flow will be (much more) linear on the inlet side and the probe (flow switch) is less likely to be affected by “low flow” that is actually seeping or “chugging” on the outlet side.
- In this position the switch may be configured to react to a *specific flow range* or to *indicate increasing/decreasing flow*.

If the flow switch has been, or must be, installed on the OUTLET side of the pump:

- The **KURZ** switch will work well as a *flow/no-flow indicator* when installed on the outlet side. However, as the turbulence will effect the switch, more care must be taken to properly configure the range (*0%/100% thermal signal*) and setpoint(s) (*relay 1 and/or 2*) to avoid false indications.
- When installed on the outlet side significant changes in fluid temperature or composition (oil to water for example) may require an adjustment to the programming of the switch.

Note: Insertion depth/probe “U length”:

The diagram below illustrates a **KURZ** flow – level – interface switch with 4” U installed in a 6” pipe in a typical top-mount pipe installation. It is extremely important to remember two (2) factors when determining the correct U length:

1. The dimension of the weldolet (1” in this example) must be added to the diameter of the pipe to correctly size the U length of the flow switch. *In this case the 4” U probe will be in the center of the 6” pipe with the 1” weldolet.*
2. If the pipe may have flow, but not be completely full, the probe must extend far enough into the pipe that the sensors are immersed.

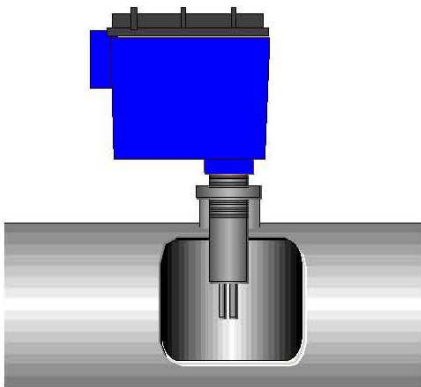

Figure 2: **KURZ GOLD 6500** with 4” U length installed in a 6” pipe with a 1” weldolet.